

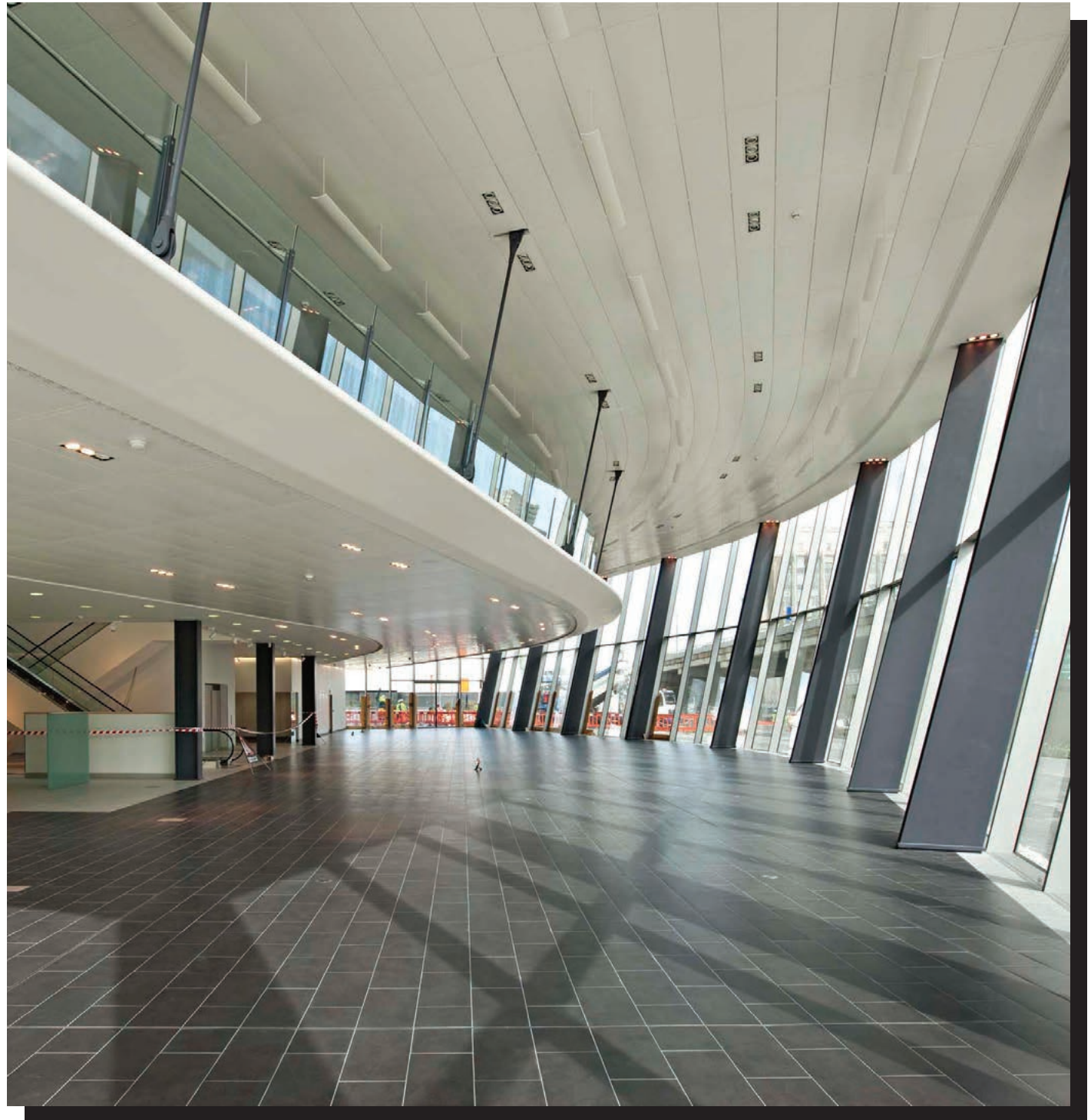

FINISHES & INTERIORS SECTOR

BEST PRACTICE GUIDE
**INSTALLATION OF
SUSPENDED CEILINGS**

www.thefis.org





FINISHES & INTERIORS SECTOR

BEST PRACTICE GUIDE **INSTALLATION OF SUSPENDED CEILINGS**

Supported by



This project has been delivered with support from the CITB Growth Fund, which aims to ensure that the construction industry has the right people, with the right skills, in the right place, at the right time and is equipped to meet the future skills demands of the industry.

First edition published January 2012

This edition published April 2015

ISBN 978-0-9565341-2-5

World copyright reserved

Copyright © 2015 FIS

Published by FIS

No part of this document may be reproduced or transmitted in any form or by any means electronic, chemical or mechanical, including photocopying, any information storage or retrieval system without licence or other permission in writing from the copyright owner.

While every care has been taken to ensure the accuracy of the details presented in this document, we regret that FIS cannot be held responsible for any errors or omissions contained herein.

CONTENTS

1 Foreword	4	4 Contract planning	9	7 Suspended ceilings and fire	23
2 Introduction	5	4.1 Integration of ceiling related services	9	7.1 Structural fire resistance	23
2.1 Scope	5	4.2 Sequence of installation	9	7.1.1 Integrity of the grid assembly	23
3 Recommendations for tendering and measurement	6	4.3 Materials management	10	7.1.2 Hold down clips	23
3.1 Contract conditions	6	4.4 Site conditions	10	7.1.3 Continuity of fire resistance	23
3.1.1 Basis of measurement	6	4.5 Setting-out points	10	7.2 Cavity barriers	24
3.1.2 Programme	6	4.6 Programme	10	8 Contracting support administration	25
3.2 Main contractor (attendances)	6	5 Setting-out the ceiling	11	8.1 Sustainability	25
3.2.1 General scaffolding	6	5.1 Setting-out and levelling	11	8.2 Health and safety	25
3.2.2 Specialist scaffolding	6	5.2 Tolerances of suspended ceilings	11	8.3 Operation and maintenance manuals	25
3.2.3 Unloading	6	5.3 Top fixings	11	9 Glossary	26
3.2.4 On site storage	7	5.4 Hangers	12	10 Acknowledgements	27
3.2.5 Temporary lighting and power	7	5.5 Installing a ceiling beneath an existing ceiling	13		
3.2.6 Working space	7	5.6 Ceiling mounted light fittings / downlighters	13		
3.2.7 Waste management	7	5.7 Appearance	14		
3.3 Design requirements	7	6 Suspended ceiling system types and installation procedures	15		
3.3.1 Drawings for tender enquiry	7	6.1 Exposed grid systems	15		
3.3.2 Specification	8	6.2 Concealed grid systems	17		
3.4 Building owner inviting tender	8	6.3 Acoustic infills for use in metal ceilings	19		
		6.4 Stretch / tensioned ceilings	19		
		6.5 Linear strip / screen ceilings	20		
		6.6 Raft / island ceilings	20		
		6.6.1 Fixed sized, pre-made rafts	20		
		6.6.2 Site constructed rafts	21		
		6.7 Acoustic baffle ceilings	21		
		6.8 Access panels	22		
		6.9 Perimeter and transition trims	22		

This guide has been developed by FIS to promote best practice in the installation of suspended ceilings.

There are very few commercial building projects, new build or refurbishment, which do not have suspended ceilings as one of their key construction components. Usually representing the largest uninterrupted surface, they make a major contribution to the overall appearance and acoustic quality of the finished space.

As a platform for lighting fixtures, HVAC diffusers, sound systems and wireless antenna panels, suspended ceilings deliver functionality to the building owner. For the construction team they offer a rapidly installed, dry and relatively clean process.

However, for the completed ceiling to meet the legitimate expectations of the building owner, occupier, design professionals and construction team, the selection and installation process must be carefully considered and understood by all parties.

Suspended ceilings are a finishing trade and require installation by specialist contractors. The specialist contractor will provide the high levels of management, operative skills and resources, essential to deliver a high quality product. Their considerable experience on similar projects will be of significant assistance to the construction team.

System manufacturers design and produce engineered ceiling systems, which are then tested to meet the requirements for various environmental and performance levels. The provision of a whole range of design solutions is part of the responsibilities taken by manufacturers, who have a key role to play in ceiling design.

FIS has grown over the past 50 years to become the leading trade association for the interiors fit out sector of the construction industry, representing companies involved in the manufacture, supply and installation of all aspects of interior fit out and refurbishment. Its members can provide optimum solutions of the installation of interior elements.

This FIS Best Practice Guide for the Installation of Suspended Ceilings is not intended as a definitive technical manual, as the manufacturers' recommendations must always be followed, but as a guide to the construction team as to best practice. FIS encourages all its members to follow the principles set out in this guide.

A satisfactory suspended ceiling installation must fulfil three main requirements:

- Appearance
- Function (performance)
- Structural stability.

These can only be achieved when the ceiling is installed under proper site conditions (see 'FIS Site Guide for Suspended Ceilings'), using the correct techniques, the right materials for the job, a high standard of workmanship and at all times adhering to health and safety regulations.

It should be noted that under no circumstances can the back of a suspended ceiling be considered a walkway or to accommodate cables ducts and trunking, which should be housed in appropriate trays, independently supported from the soffit. If a walkway in the ceiling void is required separate provision must be made.

2.1 SCOPE

This best practice guide covers the installation of all forms of suspended ceiling.

While the practices described apply equally to ceilings which are intended to provide structural fire resistance, additional requirements may have been imposed to obtain the fire endurance classification of a particular floor-ceiling construction. Such details should be obtained from the manufacturer and approved by the client / professional team before the ceiling installation begins.

Additional measures may be necessary to meet sound attenuation requirements when ceiling voids extend over adjacent rooms. This may involve the installation of sound attenuating barriers in the ceiling void or modification of the ceiling panels. The advice of the manufacturer of the acoustic materials should be sought, together with reference to the FIS publication 'A Guide to Office Acoustics'. In some cases the services of an acoustician may be required.

To enable the specialist contractor to submit a realistic tender it should be informed of the items given below. Tenders should normally be submitted on the basis that the work is to be carried out continuously; hangers, grids and panels being fixed in one operation and the work completed during one visit to site. Should more than one visit be anticipated the tenderers should be informed accordingly.

3.1 CONTRACT CONDITIONS

The form of contract, for example JCT, NEC, or bespoke form, should be stated and the relevant sections of those contracts completed (contract particulars / contract data), which will include the following particulars:

- Payments (ideally a list of due dates and final dates for payment)
- Retention (usually 3-5%)
- Discounts (it is preferable to have contracts placed on a nett of discount basis)
- Insurances
- Liquidated and ascertained damages
- Defects liability period (now called rectification period under JCT11)
- Programme (period and likely commencement date)
- Ascertainment of prices for variations
- Basis of day work charges
- Responsibility for design
- Requirements for bonds, warranties and parent company guarantees
- Waste management.

3.1.1 Basis of measurement

The basis of measurement may take one of the following forms:

- Standard Method of Measurement 7th edition (SMM7)
- New Rules of Measurement (NRM)
- Quantities taken off drawings by the specialist contractor and expressed as a lump sum (plan and spec) or an inclusive price per square metre
- Site survey by specialist contractor.

3.1.2 Programme

In addition to the information given in 3.1, as much information as is available should be given to the tenderer regarding the main contractor's building programme. If the main contractor has been appointed, ideally the ceiling tenderer should be given the dates of the work together with details of sequencing.

3.2 MAIN CONTRACTOR (ATTENDANCES)

Attendances together with services and facilities should be clearly defined before entering into final contract agreement. Both main contractor and specialist contractor should clarify in writing what they have allowed for. Good practice would be to agree a schedule, provided by either party, on what each is providing so that the situation is clear.

3.2.1 General scaffolding

General scaffolding is normally the responsibility of the main contractor. Unless otherwise stated, general scaffolding

means all scaffolding to the exterior of the building together with any scaffolding that the main contractor requires for his own use within the building. Reasonable and free use of general scaffolding and hoisting tackle already erected by the main contractor should be allowed to the specialist contractor, but general scaffolding is usually not suitable for the needs of the ceiling specialist and specialist scaffolding should be provided.

3.2.2 Specialist scaffolding

When the provision of specialist scaffolding is the responsibility of the main contractor, it should be provided, erected and dismantled free of any charge and conform to current regulations and should be erected to the specialist contractor's requirements within the agreed programme and in advance of the specialist contractor's work. It should not be dismantled before satisfactory completion of the work.

If special scaffolding is the responsibility of the specialist contractor, it is assumed that the cost is included as a separate item in the tender. The main contractor should provide sufficient space for free movement of scaffolding and a suitable floor surface to properly support the scaffolding.

3.2.3 Unloading

Unloading the specialist contractor's material and plant and distributing safely to the exact work locations should be defined as either being the responsibility of the main contractor or the specialist contractor. The former to be at the cost of the main contractor, and if the latter, the cost is deemed to be included in the specialist contractor's tender.

3.2.4 On site storage

When storage of specialist contractor's material, plant, etc is the responsibility of the main contractor, free use of a suitable secure, dry covered area of sufficient size for stacking on a flat base should be provided (see also 4.3). In the case of the specialist contractor being responsible for storage, the cost should be included in its tender.

3.2.5 Temporary lighting and power

The responsibility for the provision of suitable lighting and suitable power supply should be stated. These must be in accordance with current safety regulations. Lighting levels should be designed to allow the installation of the ceiling to be completed to the level of quality expected, particularly relevant for any ceilings where the surface will receive a finish.

3.2.6 Working space

Sufficient space should be provided free from traffic and interruption for the specialist contractor to carry out the assembly of hangers, grid components and panel cutting at floor level as part of the normal process of the work.

3.2.7 Waste management

The responsibility for clearing and removing waste material should be clearly defined pre-tender. During the suspended ceiling installation process, there can generally be the following types of waste removal:

- a** The main contractor providing waste segregation skips / bins for items such as plasterboard, mineral wool, rock / glass wool, wood, aluminium or metal, and the specialist contractor placing waste material in the relevant

skip / bin. The main contractor then takes responsibility for removal from site to a local recycling centre.

- b** The specialist contractor is asked to take responsibility to remove segregated waste, as detailed above to the recycling centre. To do this a 'waste carrier licence' is required. Without one a suitable authorised company will need to be appointed to collect the waste and transport to the local recycling centre.
- c** Recycling existing ceiling material or off cuts back to the manufacturer for recycling in the manufacturing process. This would generally be volume related, and specified by the manufacturer of the material on a minimum quantity basis. In such cases, the removed material would generally be placed on pallets, or bags which would then be collected either by the manufacturer or a waste removal company and returned to the manufacturer's plant for recycling into the manufacturing process.

Clearly, if manufacturers are not in the UK, then this method is not either cost effective or eco-friendly. At present, WRAP is working with industry to establish a more robust recycling system for all types of ceiling material.

3.3 DESIGN REQUIREMENTS

Whilst in many cases the design and product selection is carried out by the specifier to the clients' requirements, design input is being increasingly sought from the main contractor the specialist contractor and the manufacturer. So in the very early stages clarification of any design input required is needed by all parties and confirmed in writing.

3.3.1 Drawings for tender enquiry

- a** Location drawings should be provided indicating the various areas covered by the enquiry, cross-referenced to the perimeter and other details and, if required, illustrating changes in level and junctions between dissimilar materials. Minimum scale 1:200 should only be used if reflected ceiling plans (RCP) referred to in 3.3.1(b) are to a scale not less than 1:100.
- b** Where layout of ceiling panels is important, reflected ceiling plans should be included showing setting out points for the ceiling preferably to a scale 1:100 (minimum).
- c** Where recessed light fittings, grilles are to be used, these should be indicated on the drawings referred to in 3.3.1(b), together with all necessary support details including, but not limited to, the weight and manufacturers reference. Where the specialist contractor is not responsible for design, then full design details must be provided.
- d** The following information should be included:
 - Detail drawings to support design and installation
 - Level of suspended ceiling above finished floor level
 - Level of structural soffit above ceiling void or depth of suspension together with nature of soffit for top fixing of ceiling hangers
 - Lines of projection into ceiling void, eg downstand beams together with an indication of their size
 - Any other obstructions within the ceiling void eg ventilation ducts etc
 - Details of removable panels for access to services, controls etc, possibly given provisionally, together with those areas in which complete demountability is required for unobstructed access to services

- Rooflights, blind boxes, bulkheads, upstands and plasterboard margins
- Siting of sprinklers, fire detectors, access to fire dampers, air distribution outlets or other terminal equipment
- Position of partition head members
- Position and nature of cavity barriers
- Gradient of floor
- Specification of top fixing anchor.

3.3.2 Specification

The specification should state basic design criteria under the headings given below, together with outline selection of panels, supporting grid components and design loading. This is particularly important where the superimposed load of light fittings and other ceiling integrated or mounted equipment could affect the visual appearance and performance of the ceiling. It should be considered that the ceiling manufacturer is involved in assisting writing detailed specifications where appropriate.

If the design is not in general accordance with the recommendations of this guide, an official proving test may be required. In such circumstances, the designer (or specifier) should at an early stage contact the specialist contractor for recommendations and advice regarding costs of any necessary test and any work in conjunction therewith.

Design criteria should be given under the following headings (where applicable):

- System type
- Module size and thickness

- Perimeter / transition trim detail
- Degree of thermal insulation
- Sound absorption
- Sound attenuation
- Humidity resistance
- Required fire resistance
- Light reflectance level.

3.4 BUILDING OWNER INVITING TENDER

When the owner of an existing building is inviting tenders the following information should be given in addition to specification and design details:

- Location of site and access
- New building, existing building or extension
- Availability of lifts and stairs in existing buildings and use of power and hoists for bringing materials and plant into the building
- Function of building
- Main contractor's programme and building owner's stipulation affecting the sequence and working hours of the works
- Limitations imposed by occupancy on construction work.

Crucial to the success of a ceiling installation is the planning and co-ordination which precedes the work. The aim of this planning should be to establish:

EXACTLY WHAT IS TO BE DONE **SPECIFICATION**

HOW IT IS TO BE DONE **METHOD**

WHEN IT IS TO BE DONE **PROGRAMME**

These steps are inter-related and it is preferable not to discuss them separately. However, their identification will assist a methodical approach to contract planning.

All three items should have been clearly stated before tendering and indeed should have formed the basis of the tender. However, after entering into a contract it is necessary for the specialist contractor to confirm specification, method of working and programme.

The first action by the specialist contractor must be to establish the date by which materials must be ordered to meet programme requirements. This will set a limit to the time available for receipt of contract drawings, the production of specialist working drawings (if these are required) and checking and approval by the client. Where special sizes, sections, materials or finishes are involved this 'lead time' can be considerable. It is often underestimated with serious consequences if contracts are delayed, leading to claims against the specialist contractor.

Next the detailed programme of work must be agreed with the main contractor. This will include start and completion dates for the subcontract work or specific phases of the work and will be closely related to the activity of other trades whose work

can be expected to interact with the suspended ceiling.

A period of notice should be agreed for confirming or amending delivery dates.

The specifier should issue contract drawings which clearly detail the specification required and all ceiling related services. These drawings should include a fully co-ordinated reflected ceiling plan (RCP) that detail all interfaces with mechanical, electrical and related components that relate to the suspended ceiling membrane. This is to allow all services and penetrations to be shown, detailed and overlaid with the RCP. The specialist contractor should check drawings on receipt to ensure that requirements are fully understood.

Any queries must be raised with the specifier or main contractor without delay and be prepared to produce detail drawings if requested. Details which commonly require such attention include fixing of hangers to the structure, the junction of ceiling with perimeter walls, upstands, rooflight linings and head fixing of demountable partitions.

4.1 INTEGRATION OF CEILING RELATED SERVICES

It is essential at this stage that areas of potential interaction between the ceiling system and building services are identified.

These usually include:

- Dimensional co-ordination of recessed luminaires and other terminal equipment with the tile / panel module
- Additional support for light fittings, air distribution outlets, etc

- When ceiling tiles / panels are to be partially supported by light fittings or air terminal devices, that flanges are adequate and correctly dimensioned and access requirements are maintained
- Lateral stability of ceiling grid when interrupted by electrical trunking, light fittings or other ceiling level equipment
- Obstruction of hangers by heating and ventilating ductwork
- Insufficient vertical space where ductwork, recessed light fittings and / or ceiling suspension components overlap
- Location of access panels for services and clarification of headroom required for any upward opening
- Sprinkler heads coinciding with main support sections of the ceiling system
- Clarification of any co-ordination, including colour, required between ceiling grids and trims and any light fitting or speaker trims.

4.2 SEQUENCE OF INSTALLATION

When the ceiling specification and integration with the building services are established the sequence of installation and the method of working should be considered. It is necessary for all work above the ceiling to be installed before the ceiling installation commences.

Where lighting trunking or light fittings are recessed into the ceiling it may be desirable for this equipment to be installed by the specialist contractor. It may also be necessary for the ceiling panels to be installed later to give

time for air distribution and electrical connections to be made. If this sequence was not foreseen at the time of tendering it may now be necessary to negotiate new or revised rates with the specialist contractor. This only serves to emphasise the desirability of appointing specialist contractors as early as possible in the building process.

4.3 MATERIALS MANAGEMENT

For building construction to be efficient and economical the management of materials must be efficient from the point of specification to incorporation in the works. Orders must be placed with suppliers or manufacturers to allow ample time for manufacture or procurement. This is particularly important with special components or special sizes when relatively long lead times are likely.

Building programmes are commonly disrupted for a variety of reasons eg bad weather, industrial disruption affecting delivery of major components, changes of policy by clients. It is important that suppliers are kept informed of possible delays in the building programme which may require delay in delivery to site. Materials delivered too early to a site are likely to be damaged. Inadequate notice of delay may invoke charges from suppliers particularly if products ordered are being bespoke manufactured for the project.

The specialist contractor must arrange with the main contractor for the satisfactory receipt and storage of its materials. All concerned must be made aware that ceiling materials are generally fragile and require very careful handling and storage (see also 3.2.4).

4.4 SITE CONDITIONS

It cannot be too strongly emphasised that suspended ceilings are essentially a finishing trade and therefore the building should be in a proper condition with regard to cleanliness, humidity and temperature before suspended ceilings are installed. The building should be fully enclosed, all wet work completed and dried out.

In the case of wet felted mineral wool ceilings the buildings should be suitably heated and ventilated. Temporary heating or drying arrangements should be properly maintained and closely monitored. Metal and certain stone wool and glass wool products can be installed prior to the building being completely sealed from the outside elements and do not require buildings to be heated or on site acclimatised.

The manufacturer's recommended site conditions for the installation of its materials should be followed.

Suspended ceiling work is normally carried out in one operation. The prior fixing of hangers or main grids as a separate operation from the fixing of the panels will add to the cost of the installation.

Where mobile platforms are used, areas required for installation should be clean and clear of equipment and materials of other trades to provide an adequate and safe working space. The specialist contractor should leave these areas in a clean state after installation of the ceiling.

4.5 SETTING-OUT POINTS

It is essential that the setting-out points common to all trades are established early and clearly indicated on the

working drawings. It is also essential that all consultants, service contractors etc work to the same setting-out grid lines and datums and that these are established on the site by the main contractor in each ceiling area. Setting-out lines should be in both directions and squared accurately.

Designers should note that tolerances in factory made ceiling units are less than those usually accepted in building structures and it may therefore be impossible in large ceiling areas to maintain a strict alignment with modular elements such as structural columns or window mullions.

4.6 PROGRAMME

Realistic programming requires great care and depends on the professionalism and integrity of the various parties involved. In a building designed with a high concentration of services the various trades involved rely heavily on every member of the building team maintaining the correct rate of progress.

This can sometimes lead to uneconomical rates of working for some trades and consideration should be given to rationalising the work so that the specialist contractor installs equipment of other trades, for example, recessed luminaires and air terminal devices. Such rationalisation has the effect of disengaging the trades so that they rely less on each other for smooth progress and ensures co-ordination of the visible units in the ceiling.

There is a great variety of suspended ceilings and it is not intended to describe in detail precisely how to install but rather to deal with the items which are common to most ceiling systems. The manufacturer's recommendations for installation should always be followed.

5.1 SETTING-OUT AND LEVELLING

It is essential that setting-out points and datums common to all trades are provided at an early stage on the design drawings and that these are marked, together with elevation bench marks, in each ceiling area on the site by the main contractor.

It is then imperative that all trades work from the same setting-out points and datums.

The ceiling height in each ceiling area should be marked in relation to the elevation bench marks and then transferred around the area by means of water level or rotating laser levelling device that has a current calibration certificate.

Setting-out lines must be squared accurately at the outset. Care must be exercised to avoid 'creep' of tile units relative to the building module. These points are particularly critical in large ceiling areas (see 4.5).

It is important that other trades need to be made aware of the minimum clearance required to get ceiling tiles in or out on all systems.

5.2 TOLERANCES OF SUSPENDED CEILINGS

Industry has taken a view over the years that if the ceiling looks flat and no deviation in level is visible from floor level it

has been installed to acceptable tolerance (see also 4.5).

BS EN 13964 : 2004, clause A.5.2 states: 'The maximum deviation from flatness should be less than or equal to 2mm per metre length, with a maximum of 5mm over a 5m length, measured horizontally at the location of the suspension in any direction (linear interpolation is used to determine the tolerance on shorter lengths). These requirements apply for the installation of the substructure, the membrane components and the edge profiles.'

5.3 TOP FIXINGS

This is a complex area and FIS, along with the Construction Fixings Association (CFA) and other industry experts, is currently in the process of producing a guide to top fixings / anchors for suspended ceilings. It is anticipated that this will be published in May 2012.

In the interim it is recommended that the illustrated route to selection, testing and installation of correct anchors be followed.

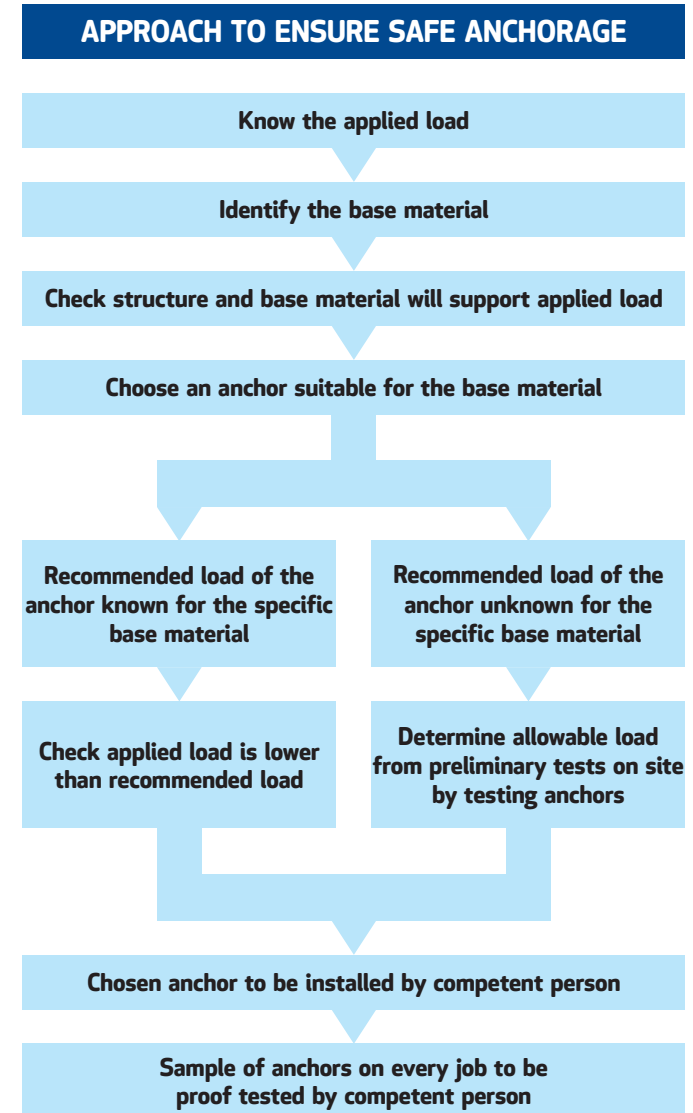

5.4 HANGERS

Hangers must always be installed as directed by the manufacturer and be spaced in accordance with the recommendations of the ceiling system manufacturer. Where additional loads such as light fittings, air handling equipment and speakers are superimposed on the ceiling, extra hangers will probably be required. The specialist contractor should check this before installation. It is the responsibility of the specialist contractor to make sure there is no additional deflection and safety is not compromised by additional weight.

Figure 1

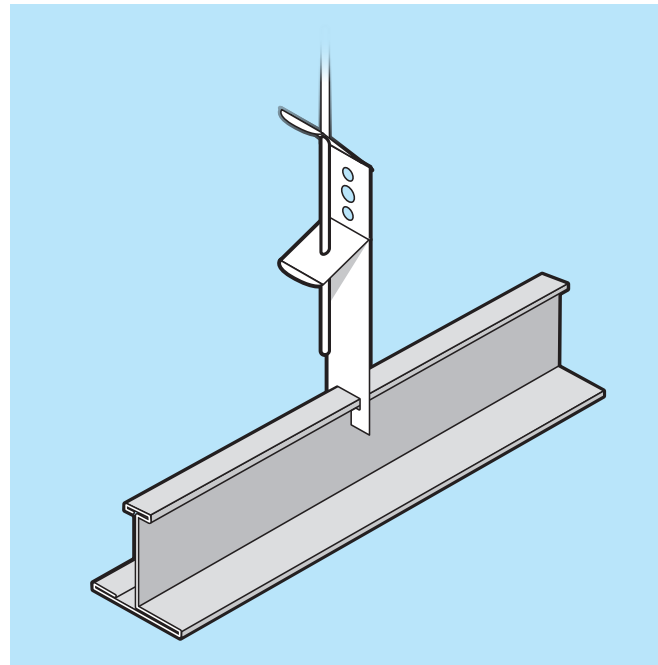
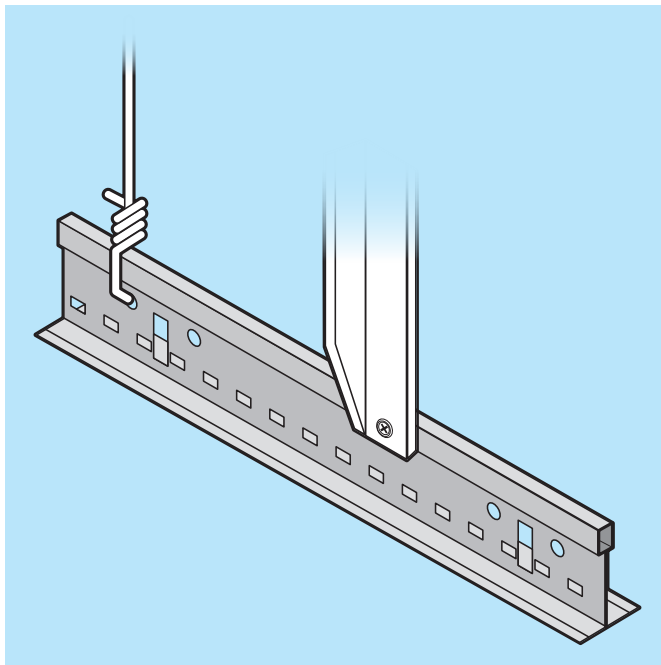

Figure 3

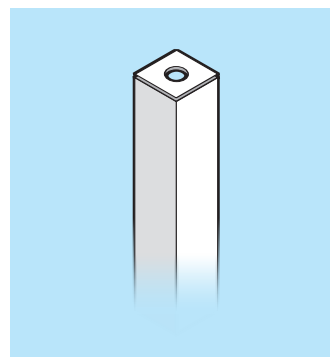

Figure 2

Wire hangers should be 2mm galvanised soft annealed wire carefully straightened by tensioning with an electric drill before use.

Mild steel galvanised angle (minimum thickness 0.80mm) or other rigid section should be used where the ceiling may be

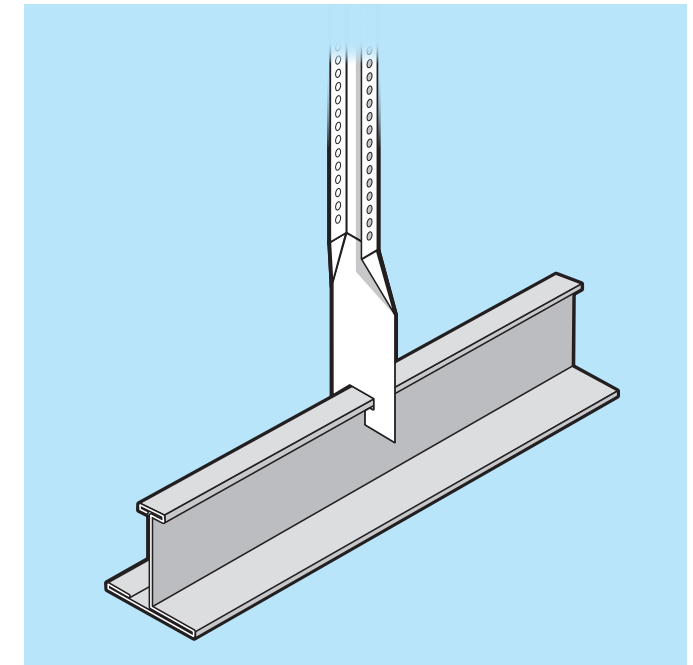

Figure 4

subject to upward movement or pressure. Care should be taken when fixing the angle hanger to the soffit to cut and bend inwardly over (at 90 degrees) both sides before punching and fixing (**see figures 1 and 2**).

Mild steel rigid galvanised slotted hangers, either single or two part connected with a pin, offer a very rigid suspension system, ideal for higher load bearing ceilings (**see figure 3**).

Threaded rod or two part rod hangers connected with an adjustment clip, make suitable hangers for ease of adjustment in level (**see figure 4**).

Hangers should generally be plumb unless the ceiling

manufacturer or site conditions otherwise dictate and should not press against insulation covering ducts, pipes or other services. If hangers must be fixed diagonally to avoid obstructions in the void, the horizontal force or lateral movement should be offset by bracing with rigid hangers.

Connection of the hanger to the load bearing component of the suspension system is critical and must be related to the point loading especially where long spanning sections are used or ceiling mounted equipment imposes additional loads.

There may be a requirement for a sub-grid to be installed between the soffit and the ceiling level. This would generally be to allow wider fixing centres to the soffit to avoid equipment in the void. In such cases a consulting engineer should be asked to determine the correct sections to use in the process.

5.5 INSTALLING A CEILING BENEATH AN EXISTING CEILING

It is not best practice to install a new suspended ceiling from an existing suspended ceiling and as such should be avoided.

On no account should ceilings be installed using existing inverted tee exposed grid systems as a primary grid for a new ceiling.

Installing an acoustic ceiling below a mass barrier such as an MF ceiling, which is common practice in cinemas, should only be undertaken if the primary anchors and MF ceiling have been designed to accept the additional load of the ceiling, including any lighting or ancillary M & E equipment. Care must be taken not to compromise the integrity or

performance of the mass barrier. Manufacturers recommendations should be taken at all times.

On new installations of double membrane ceilings it is strongly recommended that both ceilings are installed by the same specialist contractor. Where possible separate top fixings and hangers for the secondary ceiling should be installed before closing up the primary ceiling. Even when both suspended ceilings are new, evaluation of both ceiling systems, top and bottom fixings, fastening to grids and weight loadings must be carried out prior to carrying out any work.

Reuse of existing anchors

It is not best practice to use existing top fixings / anchors without proper proof testing. Evaluations must be carried out by a competent person.

5.6 CEILING MOUNTED LIGHT FITTINGS / DOWNLIGHTERS

Light fittings should be installed in any type of suspended ceiling in a manner which will not compromise the ceiling performance. Cables to fittings must not be laid directly on the back of the suspended ceiling as this could cause damage to the cables or pose unacceptable increased weight to the ceiling. Cables should therefore always be independently supported by use of cable trays, conduit or trunking. (NICEIC Technical Manual C49-13 refers).

Light fittings must not be supported from the ceiling grid if the weight of the fitting causes the total dead load to exceed the deflection limit of the ceiling suspension system.

In these cases the light fitting load must be supported by additional hangers or the light fitting should be separately supported.

The weight of modular recessed light fittings must be carried by the web of the system main section or tee grid system rather than any flanges to avoid any possible rotation of the section which would result from eccentric loading. Such light fittings can be supported from any supporting sections providing the latter are of the same section height as the main section and are supported by additional hangers.

Light fittings in concealed grid ceilings should be independently supported or if lightweight frames are used then the frame should be independently hung from the soffit.

Lighting fittings should generally not be supported directly onto the back of ceiling tiles otherwise damage or deflection could occur. A pattress (yoke) or other suitable method must be used to ensure that the load is transferred back to the grid. The overall load of the tile, fitting and pattress must not exceed the maximum load for the grid system or deflect under the weight of the light fitting.

Please note that the use of pattress materials that will not contribute to a fire in the void should be recommended ie achieve Class B-s1,d0 or better in accordance with Reaction to Fire (BS EN 13501-1) or Class 0 as described in Approved Document B of the Building Regulations.

On certain metal or gypsum ceilings, some lightweight fittings may not need any support – reference to ceiling manufacturers technical information should be made.

5.7 APPEARANCE

Where light from surface mounted light fittings or high windows strikes the ceiling at an acute angle even slight tile joint unevenness could be emphasised and may result in an unsatisfactory appearance.

In such cases bevelled edge tiles should be used in preference to square edge tiles. Alternatively if square edge tiles are desired, recessed light fittings with flush diffusers should be used so that the ceiling is lit by reflected light only.

Texture and consequently apparent colour variations may occur in deeply textured tiles. To minimise this effect it is recommended that three or four cartons of tiles are worked together and selection is random from carton to carton.

Inspection of ceilings for acceptability should only be made with lighting corresponding to that of the final building occupancy.

Within exposed and concealed grid systems in particular, there are many variations of each system type. This section has therefore to be less specific in parts and individual manufacturers product details should always be referenced prior to making a complete system choice.

All manufacturers provide recommended installation procedures for their systems and these should be considered before installation commences.

6.1 EXPOSED GRID SYSTEMS

There are generally four types of exposed grid systems:

- 1 Tee sections with a flat base of either 15mm (see figure 5) or 24mm (see figure 6).
- 2 Linear slotted based tees, either in galvanised steel with an aluminium profile or pre-painted steel attached to the base of the tee (see figures 7 and 8).
- 3 A 'C' profile main runner / cross runner sections, in varying widths, able to be constructed in linear runs or with cross runners in a tartan grid format (see figure 9).
- 4 A bandraaster section with widths of 50-150mm also able to be constructed in linear or tartan grid format (see figure 10).

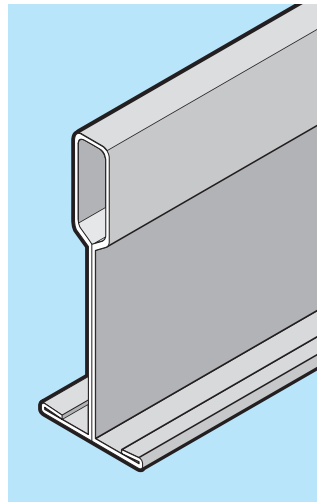

Figure 5: tee section with a flat base of 15mm

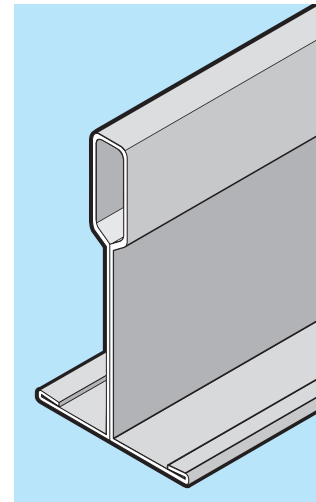

Figure 6: tee section with a flat base of 24mm

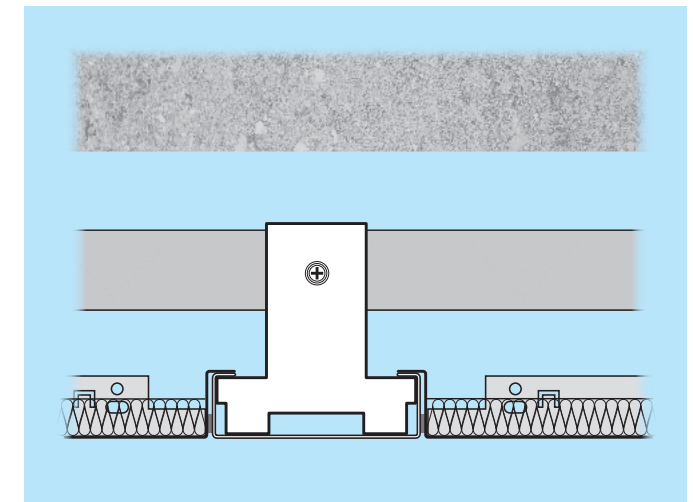

Figure 9: a 'C' profile main runner / cross runner sections

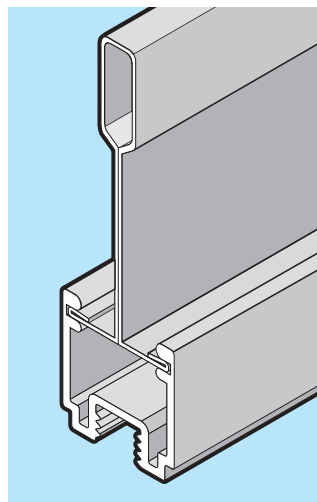

Figure 7: linear threaded base

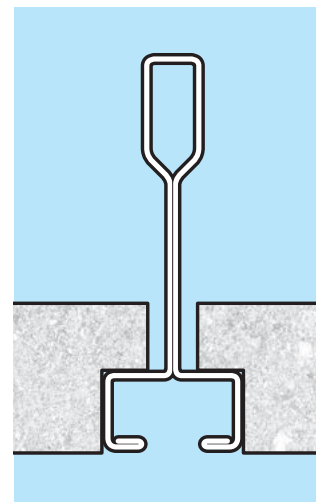

Figure 8: linear slotted base

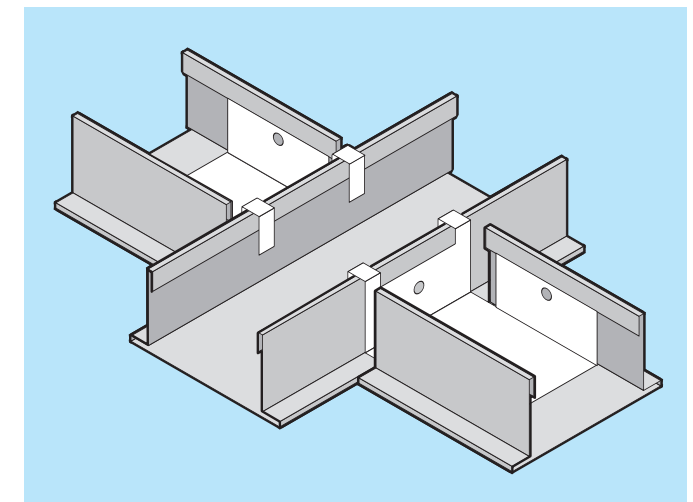

Figure 10: a bandraaster section with widths of 50-150mm

Types 1 and 2

Main runners should be installed to manufacturer's recommendations. These generally call for the hanger to be fixed to the stalk of the main runner so that they are installed to the required level (see 5.2) with supports required within 450mm of the perimeter wall and 150mm of the main runner splice. Jointing of main runners should be staggered throughout the area. Levelling must be done with the supporting hangers taut to prevent any subsequent downward movement when the ceiling loads are applied. Kinks or bends must not be made in hanger wire as a means of levelling the main runners.

Deeper main runners can be used in the same way for higher load capacities and wider spanning, or for using less hangers in standard modules (**see figure 11**).

Where a hanger wire passes through main runners the loops must be sharply bent and tightly wrapped round itself a minimum of three times and then bent upwards to a minimum of 45 degrees to prevent any vertical movement of the member within the loop and ceiling tiles being damaged in lift and tilt demounting. There must be no visually apparent angular displacement of the longitudinal axis of one runner in relation to the next runner in line with it. Either cut off any excess wire or wrap the excess around the upper part of the hanger at all times to avoid any possible eye injury or interference with the installation or removal of the ceiling tile (**see figure 12**).

Cross tees supported by either main runners or other cross tees must form a right angle with the intersecting runner. Cross tees must be flat and in plane with the flange of main runners after insertion of the panels.

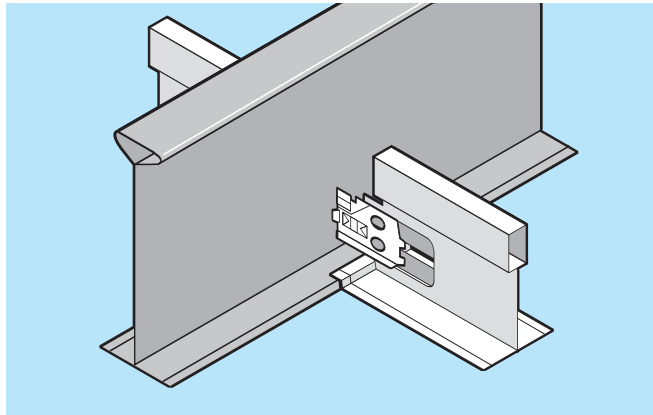

Figure 11: deeper main runners

It is recommended that cross tees over 600mm long which are cut and rest on perimeter trim be supported by an additional hanger or be fastened at their ends to the wall. This is very much dependant on the weight and hygroscopic nature of the ceiling panels.

Type 3

'C' profile systems are installed using primary channels, usually installed at 1200-1500 centres using rigid suspension hangers. The 'C' profile section, generally available in 50-300mm widths is then secured to the primary channel using suspension brackets.

The system can be used in a linear format, with panels fitted in between the 'C' profile section or in a tartan grid format, where the 'C' profile section is used as a cross runner. This hooks onto the main section, usually to form a 1200 or 1500mm module, allowing panels to be installed within.

Consultation with manufacturers is vital with this type

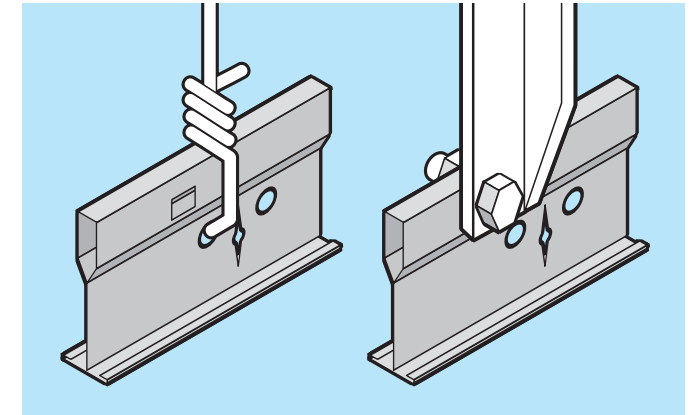

Figure 12: looping/wrapping of hanger wires; nut and bolting of galvanised angle

of system to ensure that hangers and spacings are correct for the weight imposed by the ceiling membrane as a whole.

Type 4

Bandraster systems provide a versatile exposed grid system, in widths ranging from 50-150mm and are suspended using rigid hangers.

The system can be used in linear format with main profiles installed parallel at up to 2400mm centres or in module format of up to 1250 x 1250mm. Bandraster can also be used in conjunction with standard exposed grid systems, providing greater design choice.

Types 3 and 4

The main sections can be used to carry cabling or locate partition head fixings, although this may require additional hangers to prevent lateral movement.

Hold down clips can be used to retain the panels in the grid particularly in small rooms, stairwells, entrance / reception areas where wind or air pressure may be prevalent, also for security reasons. A means of reducing potential pressure build up should be considered, eg allowing air to dissipate through lights or grilles. Where access is required the panels would not normally be clipped. Clips should be spaced according to the manufacturer's recommendations.

Non-removable panel hold down clips may have to be used in the case of a ceiling being required to provide structural fire resistance. In the case of cutting tegular or rebated edged tiles there are two alternative methods:

- 1 If the face of the grid and the perimeter trim are required to be at the same level, the tile edge should be site reformed to the rebated detail using an appropriate tool.
- 2 If the face of the tile and the perimeter trim need to be at the same level (ie the grid face is higher) then the ends of the tees should be supported by perimeter blocks (wedges).

Panels cut at perimeters must be trimmed to the full space between the last grid member and the perimeter trim to prevent subsequent movement (see 6.9).

Where the reformed tile edge is visible, it may be necessary to paint the edge with paint from the ceiling tile manufacturer.

Panels must only be handled by their edges to avoid soiling, preferably by wearing white cotton gloves. Ceiling layouts should be arranged so that panels less than one half width do not occur unless otherwise directed by reflected ceiling plans or job conditions.

An enhanced corrosion resistant grid system should be used in harsh environments, eg swimming pools, kitchens and where atmospheric conditions regularly exceed 90-95%

relative humidity, or if the environment is such that occupants have to take special precautions (ie protective clothing, masks). Also, if areas are to be subject to a high pressure cleaning regime, then this grid should be used.

6.2 CONCEALED GRID SYSTEMS

A variety of concealed ceiling systems is available that suit metal, mineral wool, gypsum, rock and glass wool products.

Systems generally incorporate a primary steel channel, from which zed, tee, hook, spring tee, spring bar, furring or other channel sections are then mechanically fixed or clipped at 90 degrees to form a fixing base for the relevant ceiling tiles (**see figures 13 to 18 overleaf**).

In general terms the typical accessibility available is shown in the table below.

	Lift and tilt	Hinge down	Downward demount	Screw fixed
Metal	✓	✓*	✓*	
Mineral wool	✓		✓	
Rock wool	✓		✓	
Glass wool	✓		✓	
Gypsum	✓			✓
Open cell	✓			

* Some with use of an accessible tool

The primary channels must be installed so that they are all to required level (see 5.2).

The levelling must be done with the supporting hangers taut to prevent any subsequent downward movement when the ceiling loads are applied. Kinks or bends must not be made in the hanger wires as a means of levelling the primary channels.

Where hanger wires are wrapped around the primary channels the wire must be wrapped around twice and then wrapped round itself a minimum of three times and bent upwards to a minimum of 45 degrees to prevent any vertical movement or rotation of the channel within the loop and ceiling tiles being damaged in lift and tilt demounting.

Rigid suspension angles and hangers are more commonly used, and should be fixed to the primary channel by either nut and bolt or tek screws. A minimum of 20mm between the fixing point and the bottom of the fixing angle should be maintained. Note that some manufacturers stipulate as part of their recommended installation procedures, that two tek screws next to each other are used per fixing point.

On some systems, splines or tee sections may be used between tiles to ensure that adjacent tiles are level and to prevent dust penetrating tile joints. This does not normally apply to tongued and grooved tiles.

All tile joints must be straight and in alignment.

Tiles surrounding recessed light fittings and similar openings must be installed with a positive method to prevent movement or displacement of the tiles.

Tiles must be installed in a uniform manner and care must be taken to avoid 'dimensional creep' by frequently checking that a given number of tiles cover the correct total

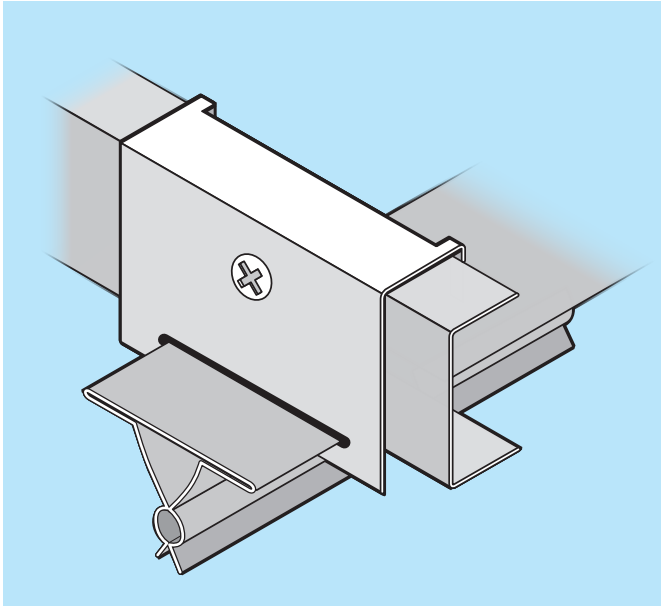

Figure 13: spring tee

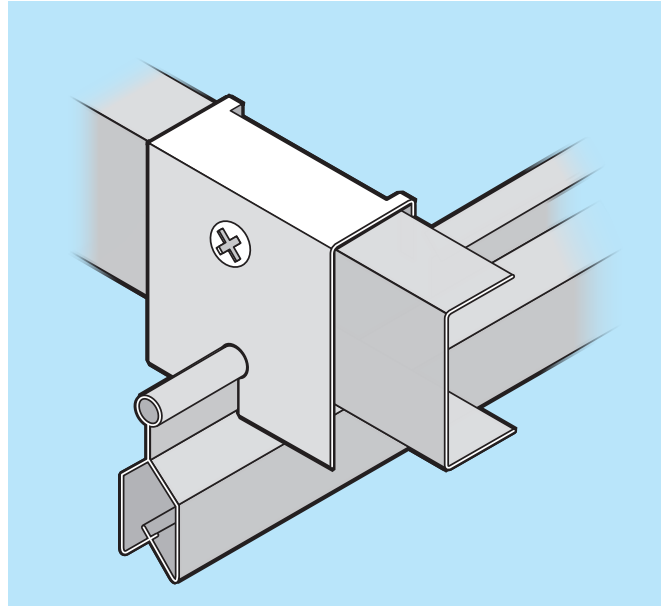

Figure 14: spring bar

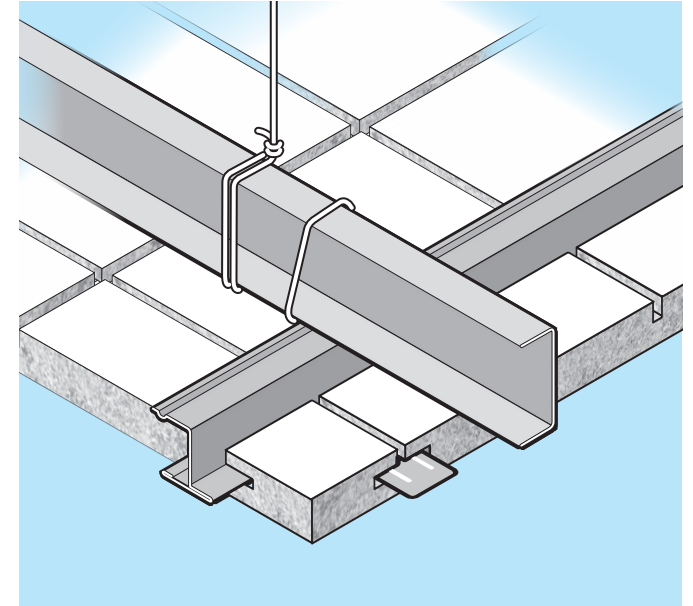

Figure 15: zed

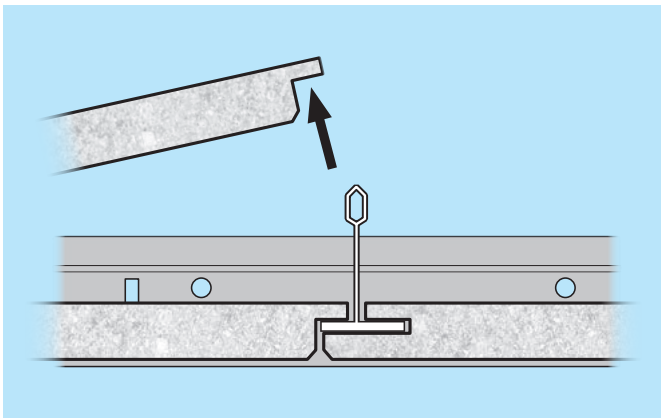

Figure 16: demountable tee

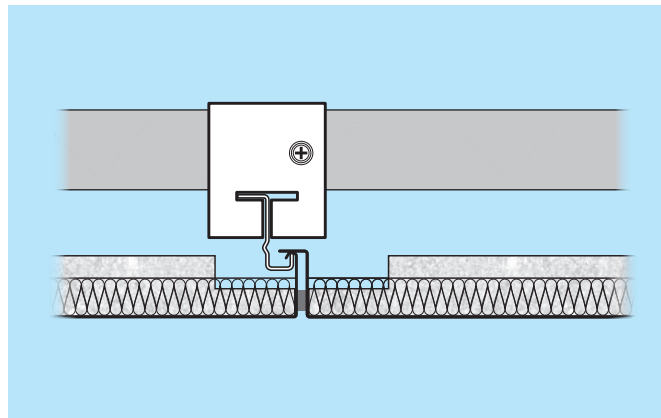

Figure 17: hook on

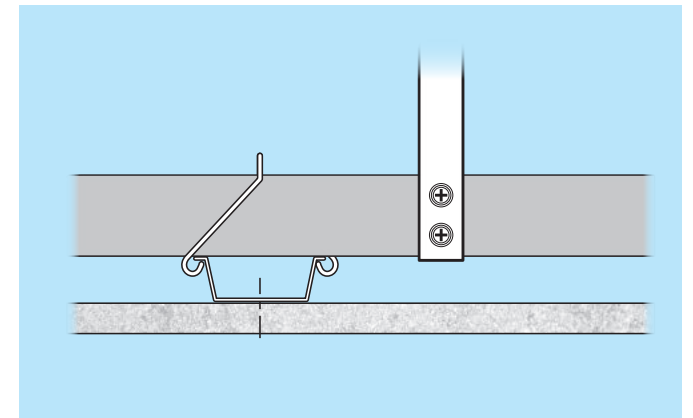

Figure 18: metal furring

dimension (see 4.5). It is recommended that a reasonable proportion of loose laid tiles are initially fixed to maintain alignment.

Removal and replacement of metal ceiling panels must be carried out correctly to avoid permanent damage through denting or twisting. Removal of tiles from clip in systems must only be done with special tools.

6.3 ACOUSTIC INFILLS FOR USE IN METAL CEILINGS

A range of acoustic infills are available to achieve numerous acoustic performance levels to suit client requirements.

When perforated acoustic metal tiles are used the acoustic pad must be fitted carefully into the back of the tile to prevent upward air movement through the panel which could cause pattern staining.

For the same reason particular care is required to ensure that pads in cut perimeter tiles are cut to the full panel size.

All cut infill pads, whether for perimeter or for cut tiles should be re-sealed along cut edges.

6.4 STRETCH / TENSIONED CEILINGS

A stretch / tensioned ceiling is a suspended ceiling system generally consisting of two components: a perimeter profile and a lightweight stretch fabric membrane or tensile fabric which is either stretched or tensioned into the perimeter profile – ie the system is suspended from its perimeter and not from overhead as traditional suspended ceilings.

These types of ceilings can also be used to create suspended

lighting / feature rafts and island features within traditional suspended ceilings (see 6.6).

Due to the flexible nature of the membrane they can be formed into virtually any shape.

These ceilings allow the incorporation of light fixtures, grilles, sprinklers etc, but as they are non-load bearing these items must be independently supported from above.

All apertures for lighting, grilles, sprinklers and other services are formed on site and may require proprietary supporting trims, frames or pattresses.

Generally, the membrane will be formed from rolls or sheet fabrics up to 2.4m wide with small ultrasonic, stitched or thermo-welded seams depending on the type of fabric used. Each manufacturer of these systems will normally have a maximum overall sheet size of between 50m² and 60m².

If the area to receive the ceiling exceeds the maximum sheet size then two or more sheets will be needed, joined together by fully or semi-concealed joining profiles that may require support from above.

Depending on the fabric used, perimeter track / profiles should be fixed to perimeter walls with suitable fixings capable of up to 30kg per linear metre tension (refer to individual manufacturer). Where the fixing is to plasterboard, securely fixed timber or metal grounds should be provided. It is recommended decorated walls have their first coat applied, tiled walls are grouted and all plastering is completed and dried prior to the installation of the perimeter tracks / profiles.

Installation of some of the fabric membranes requires the raising of the air temperature by the use of propane gas heaters to approximately 38°C in the operational area by the installer of the ceiling. In winter the areas to be fitted with

these ceilings must be heated prior to and after installation to a minimum temperature specified by the manufacturer of the system for the different fabric material fitted.

Different manufacturers may have varying procedures and recommendations due to the fabrics and tracks / profiles selected.

For occasional access to the void these ceilings are fully demountable by 'unclipping' the membrane from the perimeter profile and then 're-clipping' it back into the perimeter profile. For frequent access to the void it is recommended that demountable frames are formed out of the clip in profile and membrane are inserted into the system at required locations. In all cases consult the manufacturer for recommended procedures (see figure 19).

Figure 19: stretch

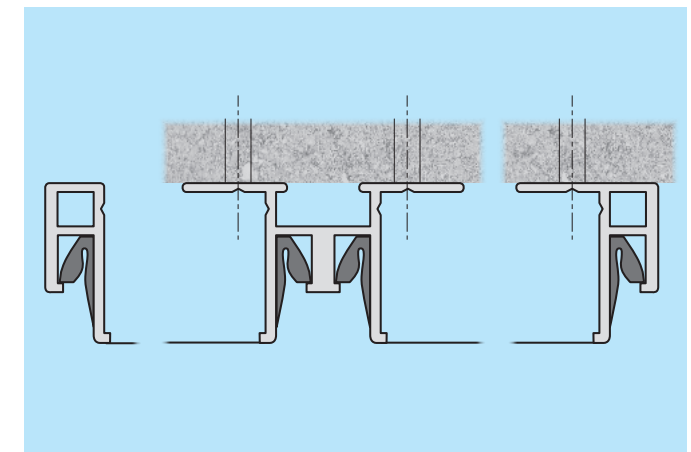

6.5 LINEAR STRIP / SCREEN CEILINGS

Strip ceilings are generally installed with the suspension of a carrier, to which the linear strip is clipped. The gap between the strips will differ with manufacturer, but generally, if required, can be closed in with an infill strip.

Acoustic material can be used in the back of the strip or as an overlay to the back of the ceiling plane (see figure 20).

Screen ceilings are installed in a similar way, but without infill strips or acoustic overlays (see figure 21).

Figure 20: linear strip

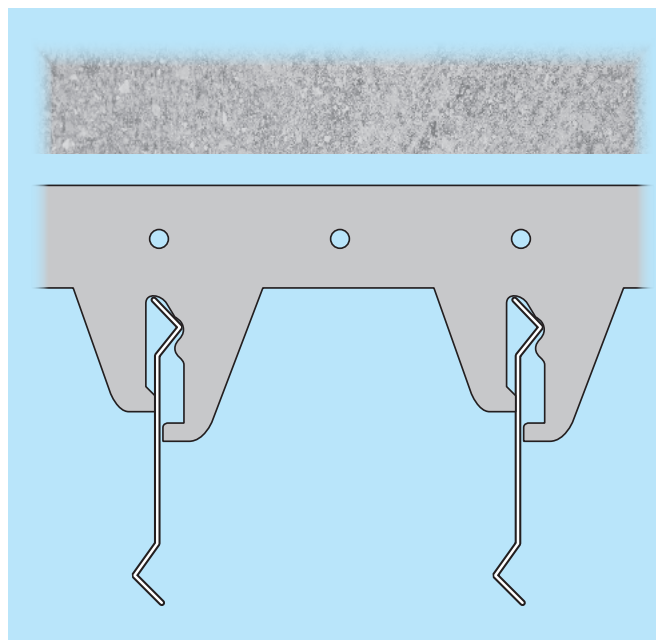
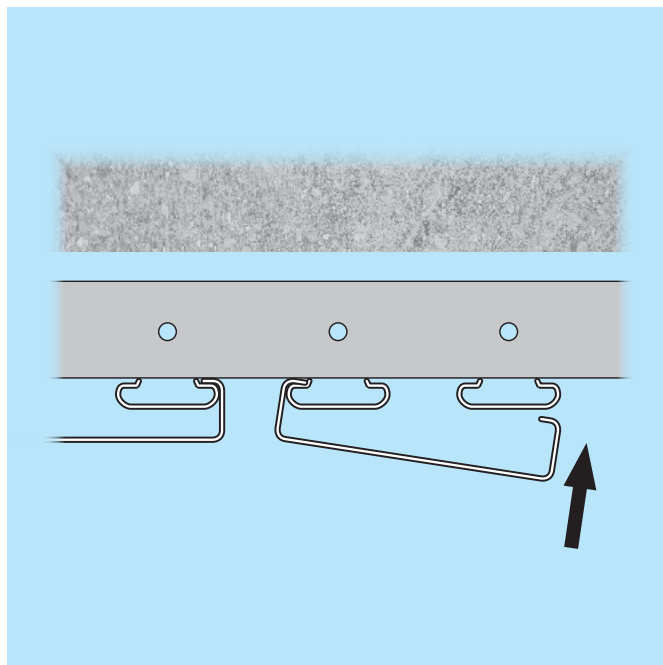

Figure 21: screen

6.6 RAFT / ISLAND CEILINGS

If the raft is being suspended from a suspended ceiling system, it is necessary to check that the suspended ceiling and its suspension system are capable of taking the extra load from the raft and that there are adequate fixing points to suspend the raft from. Rafts should be hung on vertical hangers where possible to avoid lateral load being put on the ceiling system. If this is not possible and splayed hangers are used, additional splayed hangers will need to be fitted in a 180 degree opposing direction to equalise lateral forces.

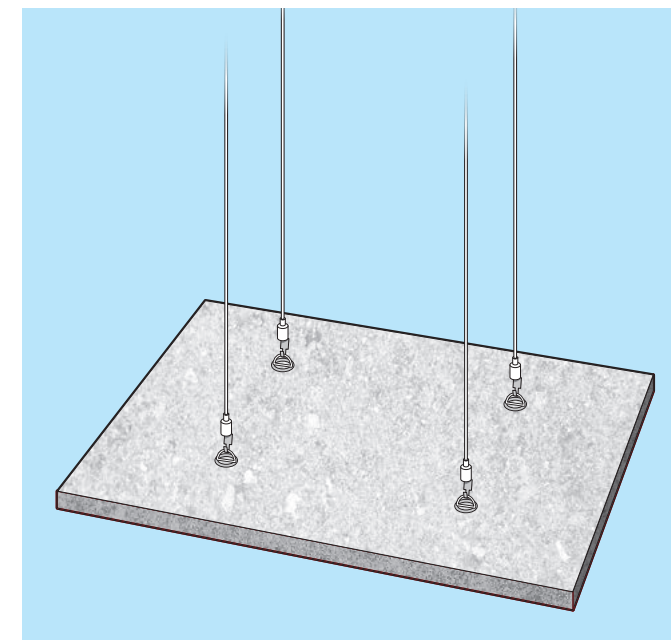

Figure 22: pre-made raft

6.6.1 Fixed sized, pre-made rafts

This is where the raft is brought to site fully constructed and ready to be suspended. The fixing points on the back of the raft are suspended either direct from the soffit or from a suspended ceiling. The suspension hangers, whether wire, cables or rigid angles, are fixed to the soffit or ceiling system and then to the rear of the raft.

Finally the raft is aligned and levelled and must be supported equally by all the suspension hangers (see figure 22).

6.6.2 Site constructed rafts

There are generally three types of this raft:

- 1 Kit form rafts that are assembled on site from pre-made aluminium / steel frame components, lay-in / hook on tiles / panels or fabric membrane then generally suspended / fixed as detailed in 6.6.1 (see figure 23).
- 2 Site manufactured using exposed grid ceiling components, deep perimeter trims and lay-in tiles as detailed in 6.1. Main runners are cut to the required width or length of the raft then infilled with cross tees and lay-in tiles. It is recommended that a series of main runners or lightweight galvanised channels are fixed diagonally at 45 degrees across the back of the grid to provide stability to the raft. (see figure 24).
- 3 Site manufactured from plasterboard / GRG panels fixed to metal furring sections utilising accepted methods and installation practices associated with these types of products. Plasterboard / GRG constructed rafts may be either taped and jointed, or skim coated with plaster or render. Additional support will be required for light fittings, speakers and sprinklers etc, when fitted to all raft types.

Figure 23: kit form raft

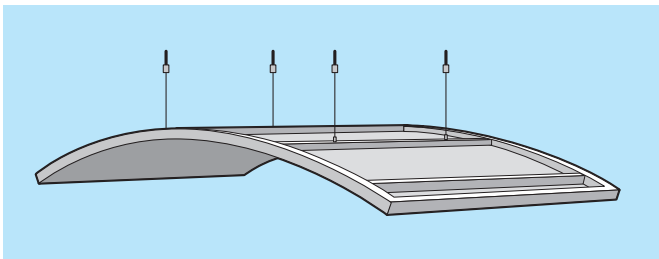
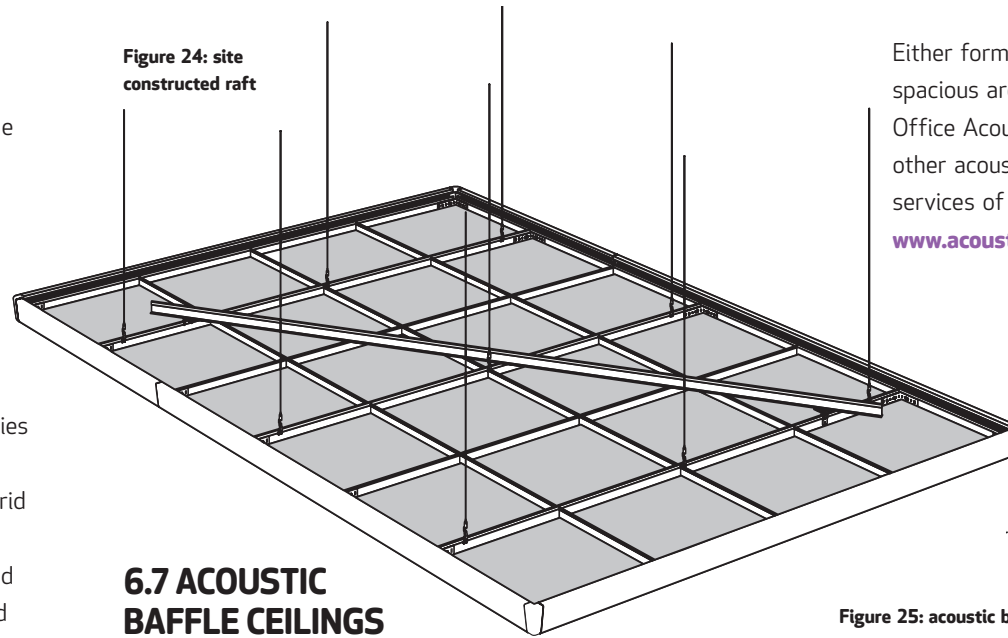

Figure 24: site constructed raft



6.7 ACOUSTIC Baffle CEILINGS

Baffles can either be fixed directly to the soffit or suspended by appropriate hangers to a required level.

When installed below a suspended ceiling it is necessary to check if the suspended ceiling system and its suspension system is capable of taking the extra load imposed by the acoustic baffles and whether it can provide adequate fixing points to suspend the baffles from. Baffles should be hung on vertical hangers wherever possible in order to avoid a lateral load being imposed to the ceiling system. Where this is not possible splayed hangers are used, and additional number of splayed hangers will be required to be fitted in a 180 degree opposed direction to equalise any lateral load imposed.

Individual baffles can be installed, or by using connecting plates, a continuous run can be formed (see figure 25).

Either format can create designed acoustic control in spacious areas. Refer to the FIS publication 'A Guide to Office Acoustics' for further information on baffles and other acoustic solutions. It may be necessary to use the services of an acoustician to provide a correct solution.

www.acousticguide.org

Figure 25: acoustic baffle

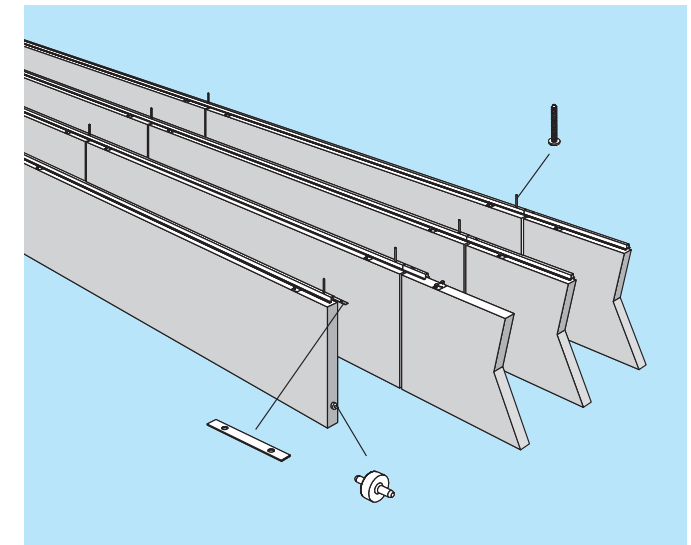

6.8 ACCESS PANELS

There is a variety of access panels available to suit all types of suspended ceiling. Generally they are constructed from steel to fit into a required opening in the ceiling membrane and provide a downward door opening for access. The doors are typically metal, but can also be faced with gypsum board or mineral / rock / glass wool to match the ceiling surround. They can be fitted with security locks if required.

The panel design broadly falls into three types:

1 A picture frame surround – allowing insertion directly into a pre-cut hole in the ceiling membrane. The structural opening needs to be +5mm to +15mm greater than the panel size, depending on manufacturer's recommendations. Independent bracing and support will be required to secure and allow safe opening of the access panel within the ceiling system. For panels greater than 600mm x 600mm it is advisable to request the use of safety chains / wires.

2 A beaded frame surround – for use in 'jointless' gypsum ceiling systems. The access panel is screw fixed through the side of the panel frame, and will require independent bracing and support which is sufficient to secure and also allow safe opening of the access panel within the ceiling system. The actual size of the structural opening in the ceiling needs to be +5mm greater than the overall panel dimensions. The fully removable door tray comes with a metal door or pre-boarded with a beaded surround. It should be inserted directly into a pre-cut hole through the face of the ceiling prior to wet finishes being applied.

3 A recessed door tray – designed to rest inside the tee section of an exposed grid ceiling. The frame will require independent bracing and must not be solely supported by the tee sections. These access panels can be fitted with a controlled action device which allows the panel door to open approximately 150mm then arresting, before being fully opened.

Whilst standard sized access panels are most popular, bespoke sized panels including circular shape can be manufactured to order.

6.9 PERIMETER AND TRANSITION TRIMS

Perimeter trim must be neatly joined at all angles. Overlap mitres (the overlapping lower section only mitred) are usually acceptable on internal and external corners. Straight run joints must be neat and adjacent lengths truly in line. Aluminium trims or channels need to be butt jointed and relevant straight and corner splices should be used to ensure alignment. All trim must be firmly fixed at the specified centres to the perimeter wall or partition. Care should be taken to avoid pieces of perimeter trim where the length is less than 600mm.

Where perimeter trims are to be fixed to surfaces or substrates which may be liable to shrinkage, such as timber or wood based battens, allowance should be made to prevent deformation or distortion of the trim occurring. Good practice would involve punching fixing holes in the perimeter trim slightly larger than the fixing screw width, to allow slight movement in the substrate. Consult manufacturers for recommendations.

For metal tiles, full size or cut perimeter tiles must be secured to ensure the face of the metal tiles sits evenly upon the perimeter trim. This is normally achieved by the use of a perimeter channel or extruded aluminium trims with cut tile border wedges. Tiles with inbuilt acoustic infills do not normally require securing, providing they are correctly and carefully cut with an appropriate high speed jig or bandsaw.

There are numerous types of perimeter and transition trim detailing available, involving all types of ceiling material with upstand / bulkhead / downstand / radiused detail, often including transition to gypsum board. All plasterboard trims should be independently supported by a hanger at correct intervals or fixed to the MF grid. At no time should they be supported by the plasterboard. All manufacturers offer drawing details of their product integrating in different ways, using different profile sections and different materials. Full consultation with manufacturers prior to project commencement will ensure the desired integration outcome.

Suspended ceilings can help to fulfil the fire requirements of the Building Regulations as follows:

- a** To contribute to the fire resistance of structural steelwork supporting a non-combustible floor.
- b** To provide added resistance to a combustible floor such as timber to enable it to satisfy the fire requirements of the Building Regulations.
- c** To increase the safety in escape routes to a degree where they may be classified as protected routes.
- d** In addition it may be necessary to install cavity barriers in the ceiling void to satisfy Building Regulations Approved Document B.

7.1 STRUCTURAL FIRE RESISTANCE

Should a suspended ceiling be intended to contribute to the structural fire resistance of a building, the tendering specialist contractors must be informed. Such ceilings may require specific materials and will need particular construction details.

Suspended ceilings that are installed for the purpose of structural fire resistance must conform in every respect to the details of the test carried out under BS EN 13501-2002. It is therefore essential that the specialist contractor has a copy of the relevant test certificate or letter of assessment which has been issued in lieu. Drawings showing construction details should be approved by an authorised member of the professional team before ceiling installation commences. The ceiling installation must conform in every respect with the tested or assessed design.

Any proposed deviation from the tested system must be

subjected to evaluation by a competent authority. Re-testing may be necessary. All parties should ensure that the test report for the specified system is still valid.

Work should be undertaken by contractors with experience of such installations, using operatives with full understanding of the fixing requirements.

7.1.1 Integrity of the grid assembly

To ensure integrity of the ceiling assembly the grid and all supporting members and fixings should be of non-combustible materials and preferably of steel.

Provision should be made within the grid sections, or at the joints of grid sections, for linear expansion resulting from the increase in temperature experienced during a fire. In the case of exposed grid systems the expansion joint in the main runner must be free to work, ie expansion joints must not be bridged or prevented from working by the installation of other construction or service elements

(see figure 26).

This means that expansion joints should not occur over a partition or directly above a surface mounted light fitting. Main runners should run tight up to walls or other substantial structures. Where this is not possible each main runner should be restrained, by bracing using a triangular configuration, to ensure the effective operation of the expansion joint. Expansion provision for concealed grid systems should be carried out in accordance with the manufacturers' fire certificate details.

7.1.2 Hold down clips

Where panel hold down clips are part of the ceiling system it

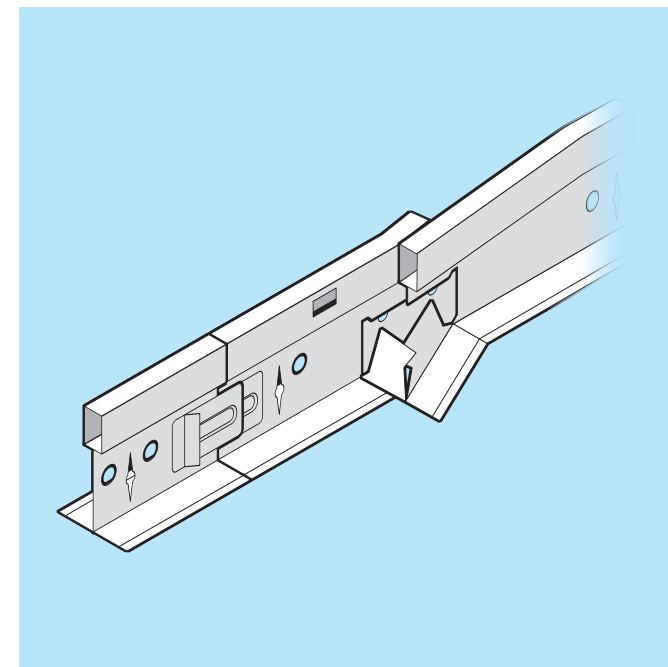

Figure 26: main runner expansion joint

is essential that the clip used will make the panel non-dismountable from the underside. Where limited access is required, removable panel clips permitting demounting of the ceiling panels from the underside can be used providing that such arrangement is covered by a certificate or assessment by a recognised test authority (see figure 27 overleaf).

7.1.3 Continuity of fire resistance

When a ceiling forms a junction with a wall for which fire resistance is required the system should be so constructed

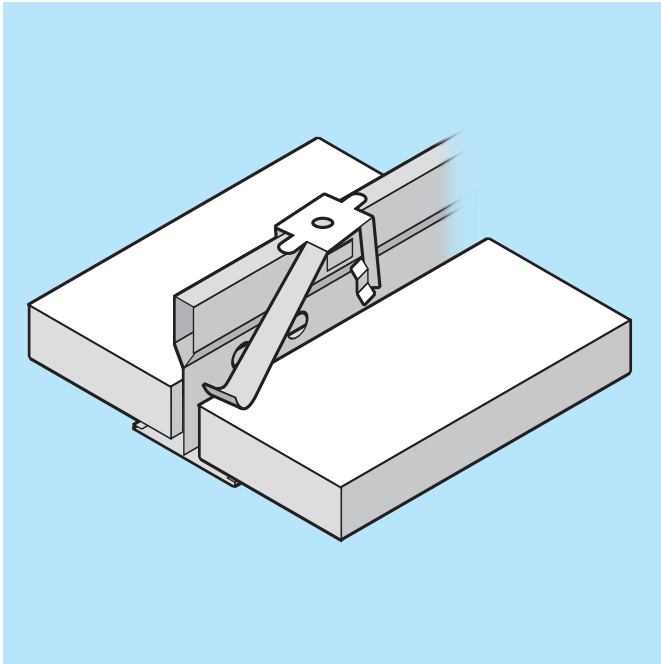

Figure 27: locking hold down clip

that the protective value of the ceiling is maintained at the junction of the ceiling and the surrounding fire resisting elements. It is therefore necessary to ensure that combustible materials or fixings are not used at the junction of the wall and ceiling system. The methods adopted in the fire test at the perimeter of the ceiling where it abuts the concrete surround of the test frame should be reproduced in service.

Surface mounted light fittings should be secured to special supports above the ceiling. However, in the case of exposed grid ceilings the light fittings may be attached to the main

runners using purpose designed connectors.

Extra hangers should be installed and the connectors should not be positioned so as to prevent expansion joints in the grid members from operating. The electrical cable from the fitting should be supported vertically above the installation. If this is not done and the fitting should fall away from the ceiling during a fire, the cable might act as a pendulum tearing the ceiling panel which would destroy the integrity of the ceiling.

Recessed light fittings may require to be either boxed-in or covered with a canopy to a specification which will maintain the integrity of the ceiling. Particular care should be taken to ensure that insulation material is not laid over the light fitting in a manner which could cause it to overheat. This could cause a deterioration in its lighting performance and possible electrical failure.

The existence of a suspended ceiling that is contributing to the structural fire protection of a building should be made known to the building owner, with instructions for its future maintenance and the preservation of its integrity.

7.2 CAVITY BARRIERS

Concealed spaces or cavities can provide a ready route for smoke and flame spread. As this spread would be concealed by the ceiling it presents a great danger.

The Building Regulations acknowledge this risk in Approved Document B Volume 2, B3 internal fire spread (structure), and provides guidance for their use, installation and material in section 9: concealed spaces (cavities). Similar provisions apply in Scotland (Technical Handbook B 2010)

APPROVED DOCUMENT B REFERENCE	Volume 2 Non dwellinghouses
Concealed spaces (cavities)	Section 9
Need to continue compartment walls up to compartment floor or roof	9.3
Fire resistance of cavity barriers	9.13

and Northern Ireland (Technical Booklet E 2005).

Cavity barriers are not appropriate to complete a line of compartmentation up through a ceiling or roof cavity. Compartmentation should be maintained by extending compartment walls up to full storey height to a compartment floor or the roof (9.3b) or use a proprietary and certified fire barrier equal to or greater than the performance of the partition, ie 30/30 or 60/60. Table 13 in Approved Document B gives guidance on the maximum dimension of 20m in any direction.

Every cavity barrier should be constructed to provide a fire resistance performance of at least 30 minutes integrity and 15 minutes insulation 30/15 (9.13).

Any penetrations should be made good with proprietary fire stopping systems to ensure the fire resistance performance of the cavity barrier is maintained. See ASFP Red Book – Fire stopping: linear joint seals, penetration seals and small cavity barriers, third edition for detailed descriptions and methodology. This can be downloaded from www.asfp.org.uk

Passive fire protection products should ideally be third party certificated and installed by contractors holding third party certification for that activity.

8.1 SUSTAINABILITY

All construction projects over a certain value will have a sustainability / carbon footprint agenda which will have to be embraced by all specialist contractors to share in the process.

As a best practice principle, all specialist contractors should have an ongoing carbon footprint reduction programme, which can then become applicable on all projects.

This will include the disposal of all materials from the strip out, and offcuts from the installation. Materials may be selected to comply with systems that are designed to measure the environmental impact of the fit out such as BREEAM, LEED or Ska (see page 26).

8.2 HEALTH AND SAFETY

To conform to the Health & Safety at Work Act 1974 the specialist contractor and main contractor must provide a method statement and risk assessment of the work that has to be undertaken on each project. All members of the construction team have a duty of care to their site colleagues. Working to agreed programmes and to formalised method statements can contribute to site safety. Identifying hazards and assessing potential risks should cover the working environment, the work to be done, the tools and equipment to be used and the materials to be installed.

Guidance can be sought from the 'FIS Health & Safety Handbook' and also the 'FIS Site Guide for Suspended Ceilings', which has particular reference to working at height.

8.3 OPERATION AND MAINTENANCE (O&M) MANUALS

When work has been completed, it is good practice to obtain signatures from the main contractor on a completion / handover certificate, to avoid later disputes on any damage subsequently caused by other trades.

If required by the terms of engagement, the main contractor must provide, either in paper form or more commonly via computer files, information relevant to the installation that has been carried out.

Typically this includes:

- Products installed
- 'As built' drawings
- Manufacturers' product information, including source of replacement material, and advice on cleaning, maintenance, repair and disposal of materials for recycling at end of life
- Acoustic and fire performance details
- Details of any special elements to the project
- Advice on removal and replacement of tiles
- Relevant COSHH data.

Maintenance

- With the exception of gypsum ceilings, most ceiling panels or tiles are factory finished and require no further decoration at the time of installation
- Cleaning should be carried out in accordance with manufacturer's recommendations
- Soiled ceilings can be cleaned by chemical spray methods available through specialist cleaning companies. In situ redecoration of some ceilings is possible. Before undertaking this, the effects on the acoustic and fire performance / characteristics should be considered.

The O&M manual is left with the main contractor who in turn makes it available to the client.

BREEAM

BREEAM is an environmental assessment method and rating system for buildings. Launched in 1990, it sets the standard for best practice in sustainable building design, construction and operation and has become one of the most comprehensive and widely recognised measures of a building's environmental performance.

A BREEAM assessment uses recognised measures of performance, which are set against established benchmarks, to evaluate a building's specification, design, construction and use. The measures used represent a broad range of categories and criteria from energy to ecology. They include aspects related to energy and water use, the internal environment (health and well-being), pollution, transport, materials, waste, ecology and management processes.

www.breeam.org

LEED

Leadership in Energy and Environmental Design (LEED) is a third-party certification program for buildings. It is a nationally accepted organisation for design, operation and construction of high performance green buildings. This ensures the buildings are environmentally compatible, provide a healthy work environment and are profitable.

LEED New Construction buildings are awarded points for sustainability for things like energy-efficient lighting, low-flow plumbing fixtures and collection of water. Recycled construction materials and energy efficient appliances also impact the point rating system.

www.leed.net

Ska

Lead and owned by the Royal Institution of Chartered Surveyors (RICS) the Ska Rating is an assessment method, benchmark and standard for non-domestic fit outs. It helps landlords and tenants assess fit out projects against a set of sustainability good practice criteria.

Ska Offices is used on fit out projects large and small, both refurbishment and new build, and it scores environmental good practice irrespective of the base building. The offices scheme consists of 104 individual good practice measures covering Energy and CO2 Emissions, Waste, Water, Materials, Pollution, Wellbeing and Transport. Ska Retail is currently under development.

This guidance is freely available along with an online assessment tool, which can be used informally or for formal certification using an RICS Ska Rating Accredited Assessor. Assessments can be carried out at three stages: design, handover and occupancy.

FIS is a Ska development partner.

www.rics.org/ska



FINISHES & INTERIORS SECTOR

FIS would like to extend its thanks to those FIS members and other professionals and specialists who gave generously of their valuable time and expertise to make this publication possible.

FIS has grown over the past 50 years to become the leading trade association for the interiors fit out sector of the construction industry. FIS represents companies involved in the manufacture, supply and installation of all aspects of interior fit outs and refurbishment.

FIS members operate in retail and commercial offices, the public sector, banks and building societies, hotels and leisure, airports, hospitals, and so on. Most work nationally and an increasing number operate in Europe and beyond.

Quality and integrity lie at the heart of FIS's philosophy - each member is expected to act with the utmost integrity, and to exercise the highest standards of business practice and workmanship. At the same time, the Association seeks to continually raise, maintain and ensure the perpetuation of standards in order to remain a source of quality membership.

FIS membership is not automatic and applicants are subject to strict vetting procedures on application, as well as ongoing vetting. In the case of contractors, this includes inspection of recent contracts to assess workmanship standards.

www.thefis.org



FINISHES & INTERIORS SECTOR

BEST PRACTICE GUIDE
**INSTALLATION OF
SUSPENDED CEILINGS**

FIS

Olton Bridge
245 Warwick Road
Solihull
West Midlands
B92 7AH

+44(0)121 707 0077
info@thefis.org
www.thefis.org

ISBN 978-0-9565341-2-5